

## NPN DARLINGTON POWER MODULE

- HIGH CURRENT POWER BIPOLAR MODULE
- VERY LOW  $R_{th}$  JUNCTION CASE
- SPECIFIED ACCIDENTAL OVERLOAD AREAS
- ULTRAFAST FREEWHEELING DIODE
- ISOLATED CASE (2500V RMS)
- EASY TO MOUNT
- LOW INTERNAL PARASITIC INDUCTANCE

### INDUSTRIAL APPLICATIONS:

- MOTOR CONTROL
- SMPS & UPS
- DC/DC & DC/AC CONVERTERS
- WELDING EQUIPMENT

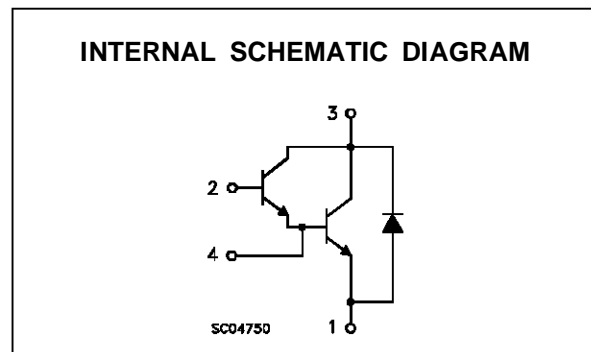
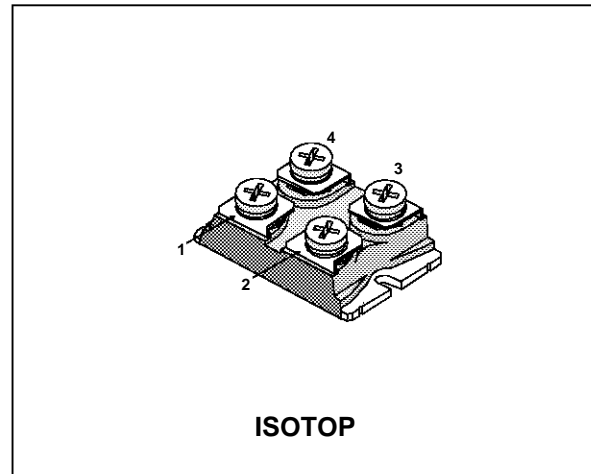

### ABSOLUTE MAXIMUM RATINGS

Symbol	Parameter	Value	Unit
$V_{CEV}$	Collector-Emitter Voltage ( $V_{BE} = -5$ V)	600	V
$V_{CEO(sus)}$	Collector-Emitter Voltage ( $I_B = 0$ )	450	V
$V_{EBO}$	Emitter-Base Voltage ( $I_C = 0$ )	7	V
$I_C$	Collector Current	84	A
$I_{CM}$	Collector Peak Current ( $t_p = 10$ ms)	126	A
$I_B$	Base Current	8	A
$I_{BM}$	Base Peak Current ( $t_p = 10$ ms)	16	A
$P_{tot}$	Total Dissipation at $T_c = 25$ °C	250	W
$T_{stg}$	Storage Temperature	-55 to 150	°C
$T_j$	Max. Operating Junction Temperature	150	°C
$V_{ISO}$	Insulation Withstand Voltage (AC-RMS)	2500	V

## ESM6045DV

### THERMAL DATA

$R_{thj-case}$	Thermal Resistance Junction-case (transistor)	Max	0.5	$^{\circ}\text{C}/\text{W}$
$R_{thj-case}$	Thermal Resistance Junction-case (diode)	Max	1.2	$^{\circ}\text{C}/\text{W}$
$R_{thc-h}$	Thermal Resistance Case-heatsink With Conductive Grease Applied	Max	0.05	$^{\circ}\text{C}/\text{W}$

### ELECTRICAL CHARACTERISTICS ( $T_{case} = 25^{\circ}\text{C}$ unless otherwise specified)

Symbol	Parameter	Test Conditions	Min.	Typ.	Max.	Unit
$I_{CER} \#$	Collector Cut-off Current ( $R_{BE} = 5 \Omega$ )	$V_{CE} = V_{CEV}$ $V_{CE} = V_{CEV} \quad T_j = 100^{\circ}\text{C}$			1.5 22	mA mA
$I_{CEV} \#$	Collector Cut-off Current ( $V_{BE} = -5$ )	$V_{CE} = V_{CEV}$ $V_{CE} = V_{CEV} \quad T_j = 100^{\circ}\text{C}$			1 15	mA mA
$I_{EBO} \#$	Emitter Cut-off Current ( $I_C = 0$ )	$V_{EB} = 5 \text{ V}$			1	mA
$V_{CEO(SUS)}^*$	Collector-Emitter Sustaining Voltage	$I_C = 0.2 \text{ A} \quad L = 25 \text{ mH}$ $V_{clamp} = 450 \text{ V}$	450			V
$h_{FE}^*$	DC Current Gain	$I_C = 70 \text{ A} \quad V_{CE} = 5 \text{ V}$		120		
$V_{CE(sat)}^*$	Collector-Emitter Saturation Voltage	$I_C = 50 \text{ A} \quad I_B = 1 \text{ A}$ $I_C = 50 \text{ A} \quad I_B = 1 \text{ A} \quad T_j = 100^{\circ}\text{C}$ $I_C = 70 \text{ A} \quad I_B = 4 \text{ A}$ $I_C = 70 \text{ A} \quad I_B = 4 \text{ A} \quad T_j = 100^{\circ}\text{C}$		1.2 1.6 1.35 1.7	2 2	V V V V
$V_{BE(sat)}^*$	Base-Emitter Saturation Voltage	$I_C = 70 \text{ A} \quad I_B = 4 \text{ A}$ $I_C = 70 \text{ A} \quad I_B = 4 \text{ A} \quad T_j = 100^{\circ}\text{C}$		2.3 2.4	3	V V
$di_C/dt$	Rate of Rise of On-state Collector	$V_{CC} = 300 \text{ V} \quad R_C = 0 \quad t_p = 3 \mu\text{s}$ $I_{B1} = 1.5 \text{ A} \quad T_j = 100^{\circ}\text{C}$	375	450		A/ $\mu\text{s}$
$V_{CE(3 \mu\text{s})}$	Collector-Emitter Dynamic Voltage	$V_{CC} = 300 \text{ V} \quad R_C = 6 \Omega$ $I_{B1} = 1.5 \text{ A} \quad T_j = 100^{\circ}\text{C}$		6	9	V
$V_{CE(5 \mu\text{s})}$	Collector-Emitter Dynamic Voltage	$V_{CC} = 300 \text{ V} \quad R_C = 6 \Omega$ $I_{B1} = 1.5 \text{ A} \quad T_j = 100^{\circ}\text{C}$		3	4.5	V
$t_s$	Storage Time	$I_C = 50 \text{ A} \quad V_{CC} = 50 \text{ V}$		3.5	5.5	$\mu\text{s}$
$t_f$	Fall Time	$V_{BB} = -5 \text{ V} \quad R_{BB} = 0.3 \Omega$		0.3	0.5	$\mu\text{s}$
$t_c$	Cross-over Time	$V_{clamp} = 450 \text{ V} \quad I_{B1} = 1 \text{ A}$ $L = 0.05 \text{ mH} \quad T_j = 100^{\circ}\text{C}$		0.8	1.7	$\mu\text{s}$
$V_{CEW}$	Maximum Collector Emitter Voltage Without Snubber	$I_{C\text{Woff}} = 84 \text{ A} \quad I_{B1} = 4 \text{ A}$ $V_{BB} = -5 \text{ V} \quad V_{CC} = 50 \text{ V}$ $L = 0.03 \text{ mH} \quad R_{BB} = 0.3 \Omega$ $T_j = 125^{\circ}\text{C}$	450			V
$V_F^*$	Diode Forward Voltage	$I_F = 70 \text{ A} \quad T_j = 100^{\circ}\text{C}$		1.6	1.9	V
$I_{RM}$	Reverse Recovery Current	$V_{CC} = 200 \text{ V} \quad I_F = 70 \text{ A}$ $di_F/dt = -375 \text{ A}/\mu\text{s} \quad L < 0.05 \mu\text{H}$ $T_j = 100^{\circ}\text{C}$		38	45	A

\* Pulsed: Pulse duration = 300  $\mu\text{s}$ , duty cycle 1.5 %

# See test circuits in databook introduction

To evaluate the conduction losses of the diode use the following equations:

$$V_F = 1.5 + 0.0055 I_F \quad P = 1.5 I_{F(AV)} + 0.0055 I_{F(RMS)}^2$$

Safe Operating Areas

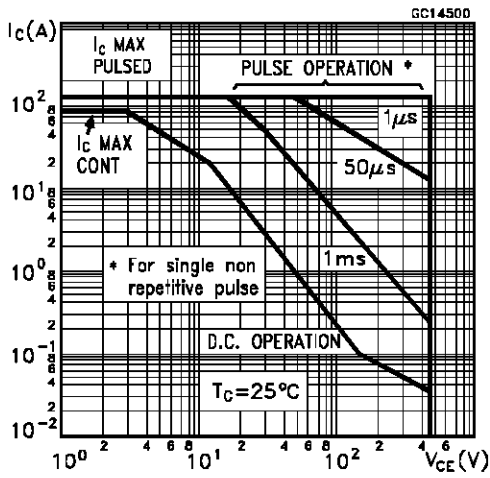

Thermal Impedance

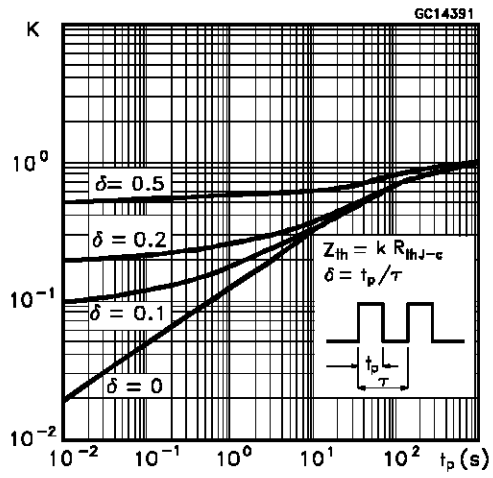

Derating Curve

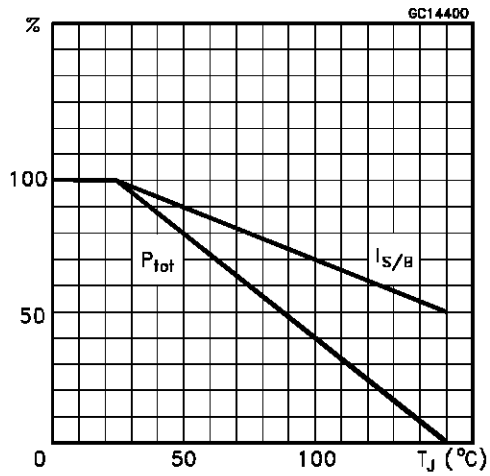

Collector-Emitter Voltage Versus Base-Emitter Resistance

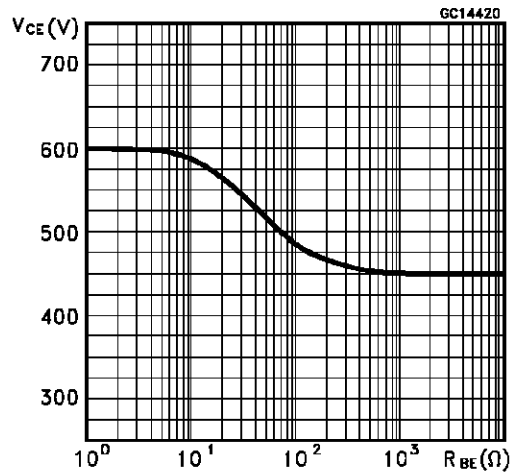

Collector-Emitter Saturation Voltage

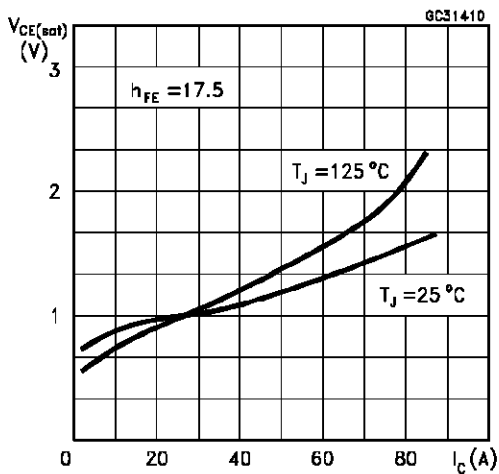

Base-Emitter Saturation Voltage

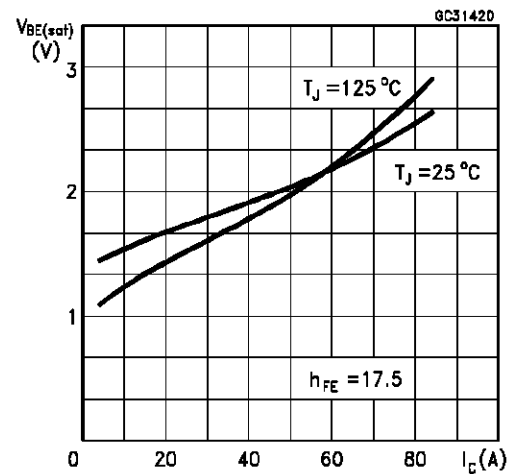

Reverse Biased SOA

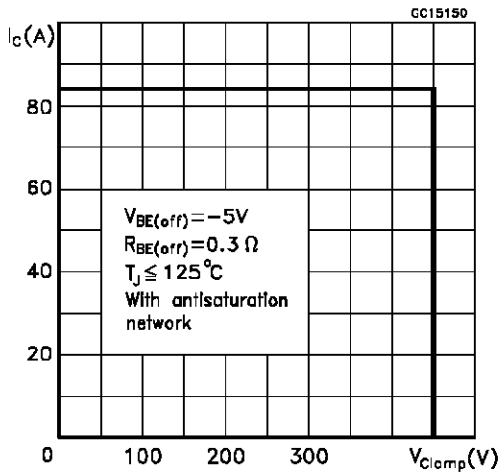

Forward Biased SOA

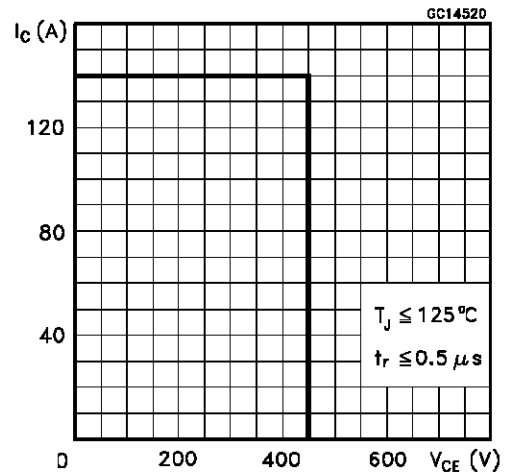

Reverse Biased AOA

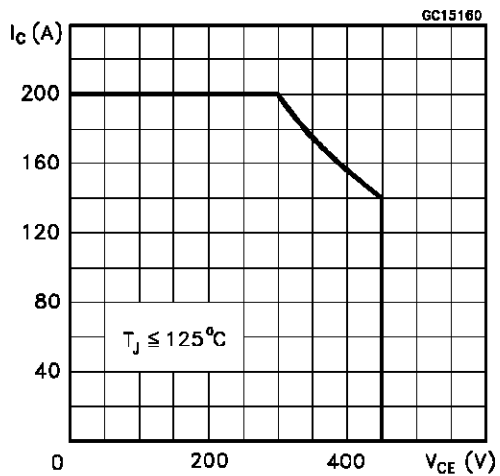

Forward Biased AOA

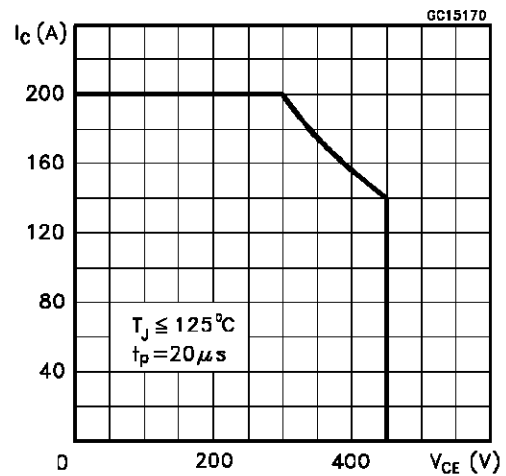

Switching Times Inductive Load

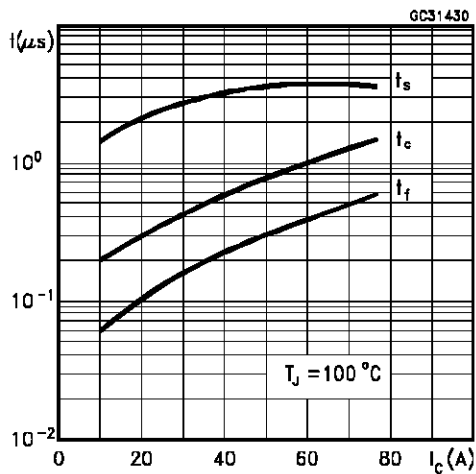

Switching Times Inductive Load Versus Temperature

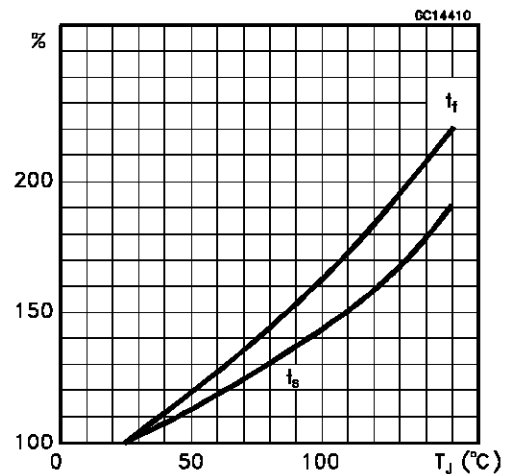

DC Current Gain

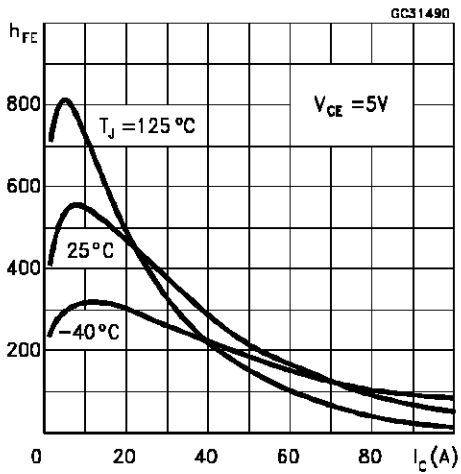

Typical  $V_F$  Versus  $I_F$

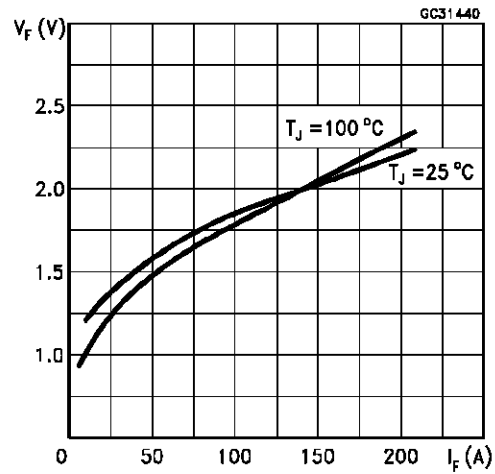

Peak Reverse Current Versus  $di_F/dt$

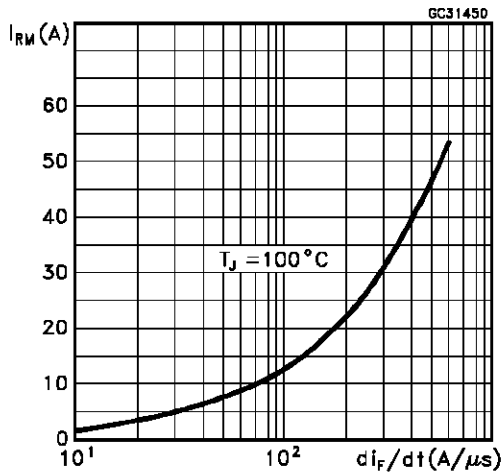

Turn-on Switching Test Circuit

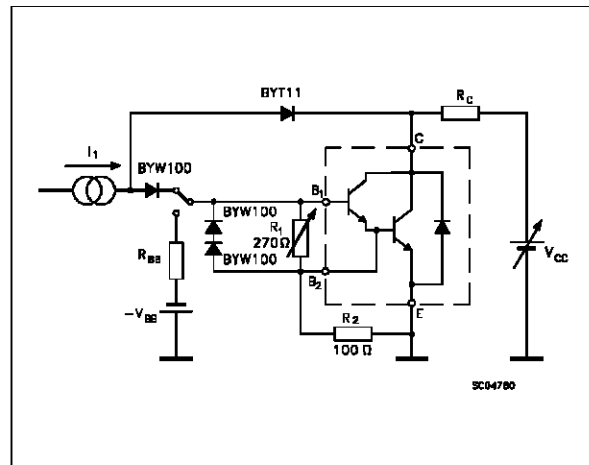

Turn-on Switching Waveforms

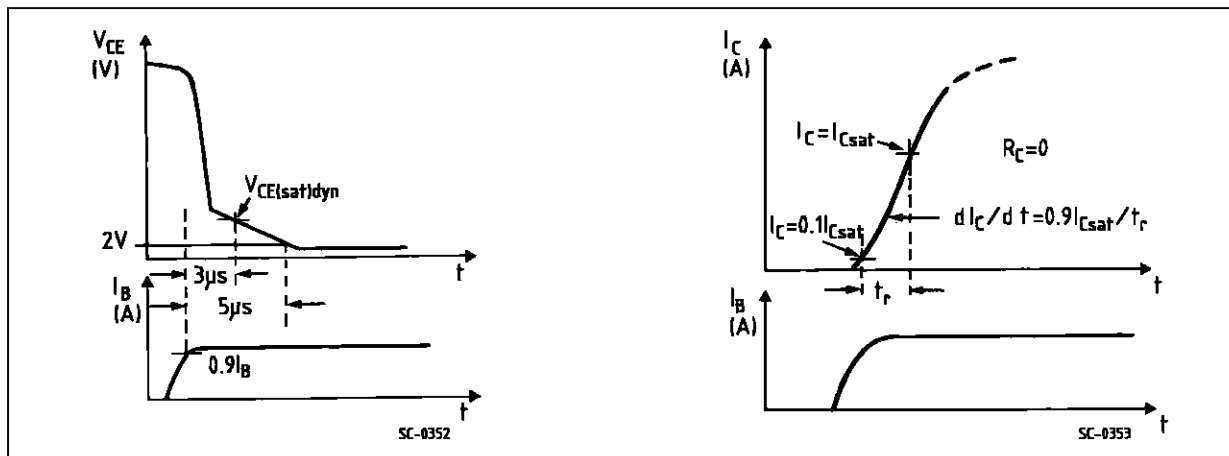

Turn-off Switching Test Circuit

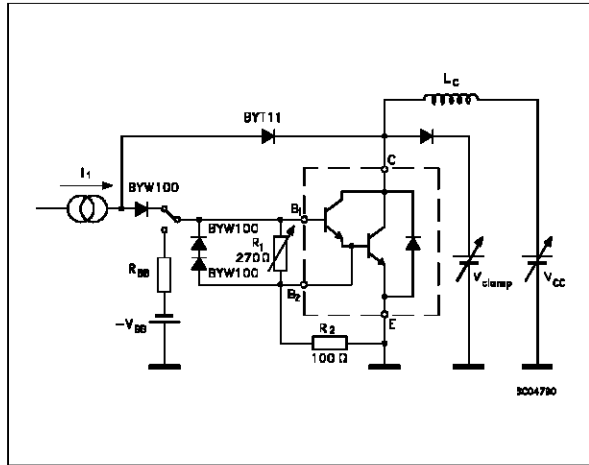

Turn-off Switching Waveforms

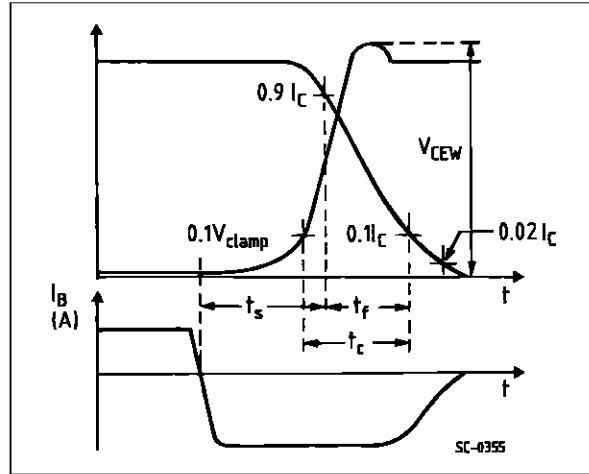

Turn-off Switching Test Circuits of Diode

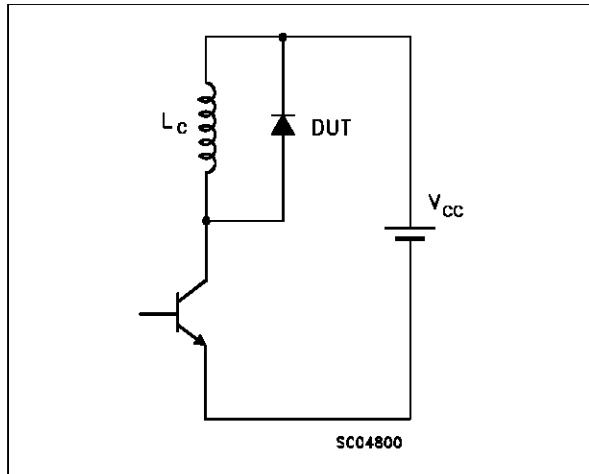

Turn-off Switching Waveform of Diode

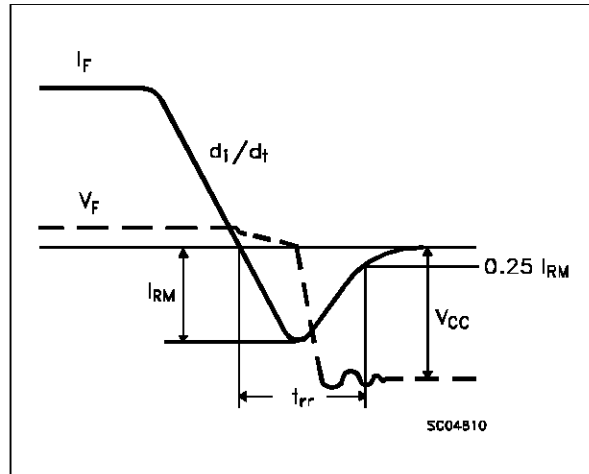

**ISOTOP MECHANICAL DATA**

DIM.	mm			inch		
	MIN.	TYP.	MAX.	MIN.	TYP.	MAX.
A	11.8		12.2	0.466		0.480
B	8.9		9.1	0.350		0.358
C	1.95		2.05	0.076		0.080
D	0.75		0.85	0.029		0.033
E	12.6		12.8	0.496		0.503
F	25.15		25.5	0.990		1.003
G	31.5		31.7	1.240		1.248
H	4			0.157		
J	4.1		4.3	0.161		0.169
K	14.9		15.1	0.586		0.594
L	30.1		30.3	1.185		1.193
M	37.8		38.2	1.488		1.503
N	4			0.157		
O	7.8		8.2	0.307		0.322
P	5.5			0.216		

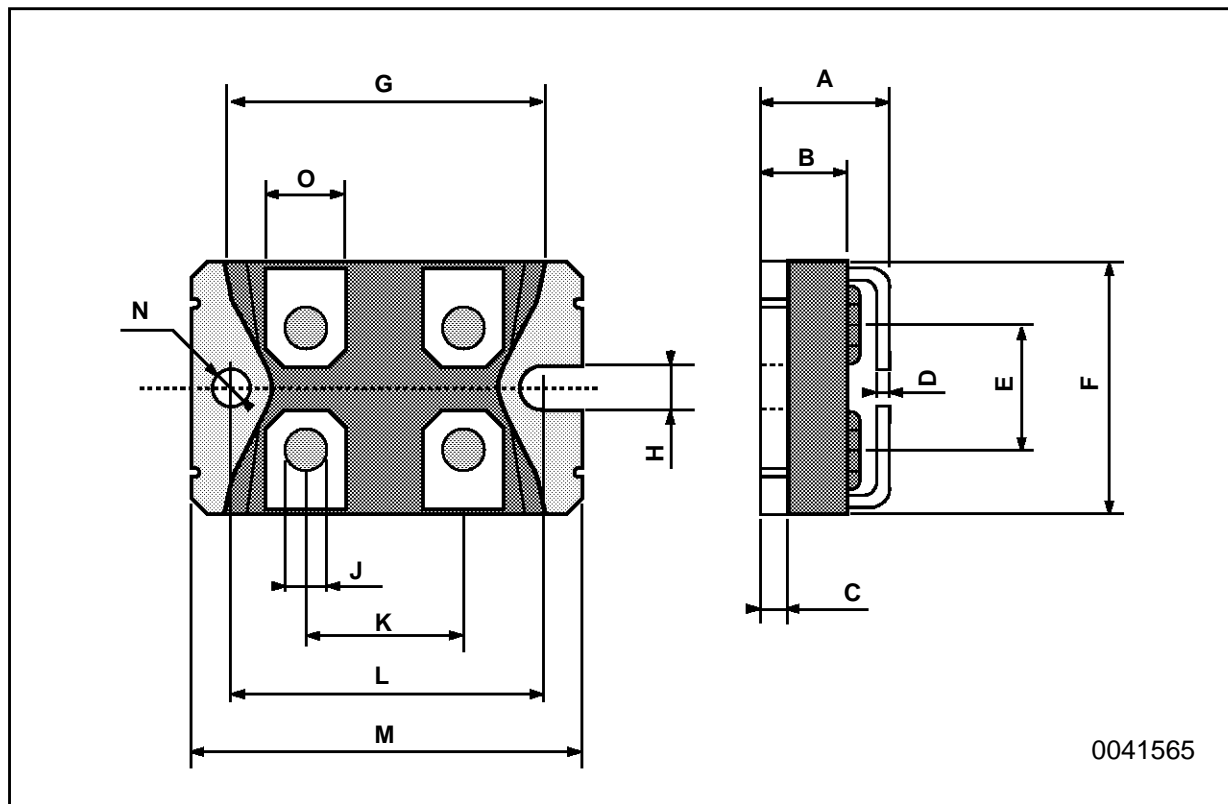

Information furnished is believed to be accurate and reliable. However, SGS-THOMSON Microelectronics assumes no responsibility for the consequences of use of such information nor for any infringement of patents or other rights of third parties which may result from its use. No license is granted by implication or otherwise under any patent or patent rights of SGS-THOMSON Microelectronics. Specifications mentioned in this publication are subject to change without notice. This publication supersedes and replaces all information previously supplied. SGS-THOMSON Microelectronics products are not authorized for use as critical components in life support devices or systems without express written approval of SGS-THOMSON Microelectronics.

© 1994 SGS-THOMSON Microelectronics - All Rights Reserved

SGS-THOMSON Microelectronics GROUP OF COMPANIES  
Australia - Brazil - France - Germany - Hong Kong - Italy - Japan - Korea - Malaysia - Malta - Morocco - The Netherlands -  
Singapore - Spain - Sweden - Switzerland - Taiwan - Thailand - United Kingdom - U.S.A